



Fresh ideas in foodservice equipment



BKI's FS Rotisserie shown above



Electric Rotisserie

Model: FS

Countertop Electric Rotisserie Oven with Touchpad Controller

Perfect for delis, convenience stores and quick-serve restaurants, BKI's countertop rotisserie utilizes valuable counter space with a 'hot-hold' feature to enhance product merchandising and profitability. Serve your customers self-basted chicken, buffalo wings, turkey breasts or ribs cooked perfectly time and time again with BKI's versatile rotisserie. Excellent lighting promotes eye appeal and helps maintain optimum temperature so your customers keep coming back for more

Standard Features:

- Capacity – up to 9 – 3lb/1.36kg chickens
- High visibility with attractive design
- Compact unit for small spaces
- Single stage cook and hold computer with 5 customizable cook programs
- Removable rotors for easy cleaning
- Easy removable fat collection tray
- Lighted theatre for maximum customer attraction
- Removable stainless steel parts for ease of cleaning
- External Material (18 gauge, 304 Stainless Steel)

BKI North America
PO Box 80400
Simpsonville, SC 29680-0400 USA
Telephone: (864) 963-3471
Toll Free: (800) 927-6887

BKI Europe
Theale Technology Centre
Station Road • Theale
Reading • West Berkshire • RG7 4AA
Telephone: 0870 9904242 • Fax: 0870 9904243



Electric Rotisserie (FS)

Equipment Dimensions:

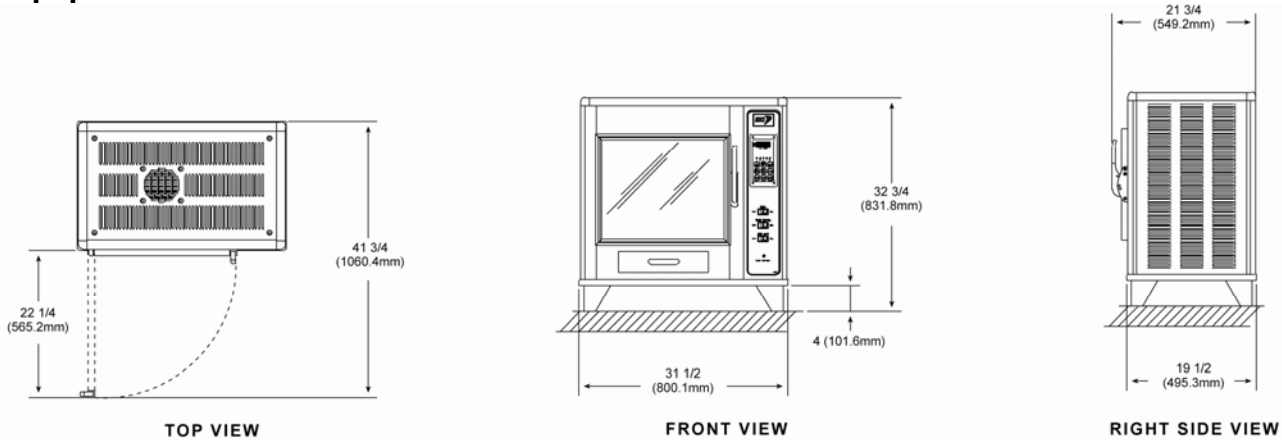

Mechanical Specifications:

Dimension	Uncrated	Crated
Height	32.75" (831.8 mm)	41.5" (1056 mm)
Width	31.5" (800.1 mm)	24.5" (623.4 mm)
Depth	19.5" (495.3 mm)	35" (890.6 mm)
Floor Space	4.3 sq. ft. (.39 sq. m)	6 sq. ft. (.55 sq. m)
Weight	180 lb. (81.6 kg)	195 lb. (88.5 kg)

Electrical Options:

Volts	Amps	KW	Breaker	Wires	Phase
120	25	3	35	2	1
120/208	15	3	20	3	1
208-22/240	15.4/13.2	3.2	20	2	1
220/240/50Hz	12.5/13.35	2.75/3.2	20	2	1
230/50Hz	13.9	3.2	20	2	1

Accessories

- MEAT BASKET (MB0007)
- MEAT FORK 20.75 (MF0002)
- 13" insulating mitts (G0052)

Options

- Pass-thru or solid back
- Legs or tabletop

BKI North America
 PO Box 80400
 Simpsonville, SC 29680-0400 USA
 Telephone: (864) 963-3471
 Toll Free: (800) 927-6887

BKI Europe
 Theale Technology Centre
 Station Road • Theale
 Reading • West Berkshire • RG7 4AA
 Telephone: 0870 9904242 • Fax: 0870 9904243

 **Standex**
 Food Service Equipment Group