

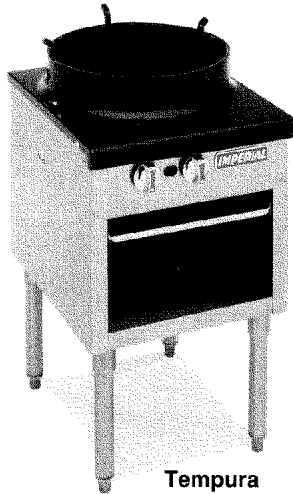

Specialty Cooking Equipment

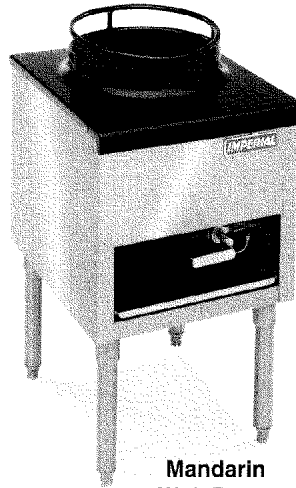

**Tempura
Wok Range**
Model# ISP-18W



**Mandarin
Wok Range**
Model# ISP-J-W13



**Hi-Temp
Stock Pot Range**
Model# ISP-J-SP

Standard Features

- Stainless steel front, sides and cabinet.
- Full width drip pan for easy clean-ups.
- One year parts and labor warranty.
- AGA and CGA design certified and NSF Certified.

Tempura Wok Range

- Three-ring burner with two adjustable gas valves provides 90,000 BTU/hr. for high performance cooking.
- Heating selections from simmer to high heat.
- 16" wok opening holds an 18" wok.
- Stainless steel cabinet base provides additional storage.

Mandarin Wok Range

- Non-clogging 18 tip jet burner provides cone-shaped intense heat with 125,000 BTU/hr output.
- 13" slanted wok opening for 14" wok pans. Also available with 16" opening.
- Stainless steel cabinet base provides additional storage. Wok top is made of all-welded 12 gauge steel.

Hi-Temp Stock Pot Range

- Non-clogging 18 tip jet burner is rated 125,000 BTU/hr. Continuous pilot provides instant ignition.
- Heavy duty cast iron top grate has welded-in cylinder to concentrate heat. Roll front is easy to load and gradual slope design reduces spill-overs.
- 6" legs with adjustable feet are standard.

Imperial Specialty Cooking Equipment

Imperial provides as standard many of the optional upgrades normally offered at a premium on other cooking equipment lines. The new look features a stainless steel front, sides and cabinet. Multiple burner options offer high performance cooking for the varied requirements of these specialty styles of cooking.

The Tempura Wok Range is designed for tempura, stir-fry and steamed oriental cooking. It is also perfect for catering and exhibition cooking with 90,000 BTU/hr.

The Mandarin Wok Range has a slanted wok holder with a 13" opening. It holds a 14" single handle wok pan. The 125,000 BTU/hr. output provides the cone-shaped intense heat to sear-in authentic flavors perfect for Mandarin menu items. A removable, full width drip pan makes clean-ups quick and easy.

The Hi-Temp Stock Pot Range has a 125,000 BTU/hr. non-clogging jet burner. The top grate has a cylinder welded-in to contain and concentrate the heat. The cylinder is 14" dia. and 12" deep. The heavy duty cast iron grate is designed with a roll front for easy loading. It also has a gradual slope to reduce spill-overs and will accommodate any size stock pot. For quick clean-ups a full width, removable drip tray is standard.

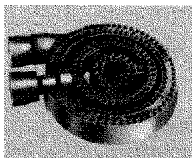

3-Ring Burner

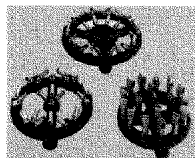

Jet Burners



Specialty Cooking Equipment

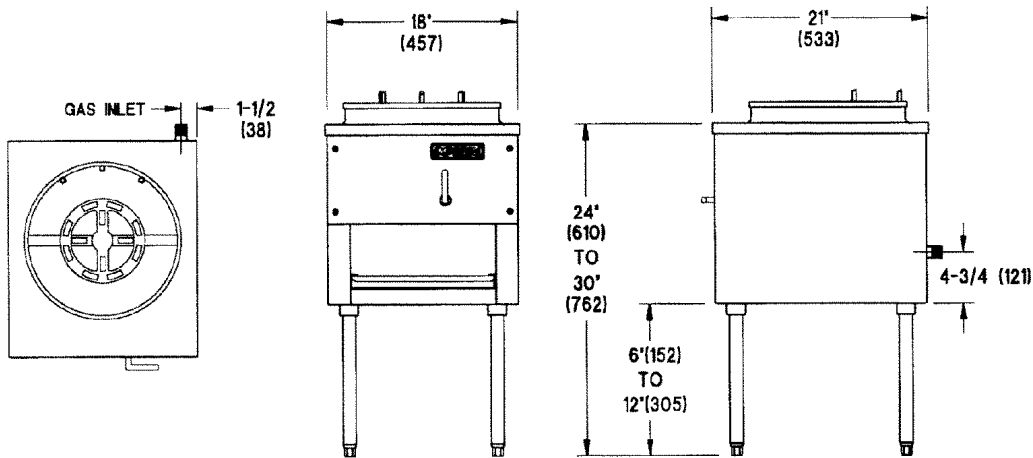

Imperial Specialty Cooking Equipment

Model#	Width	Height	Description	Burner	B.T.U.	Ship Weight	
						(Kg)	(Lbs)
ISP-18W	18"	30"	16" Opening	(1) 3-Ring Burner	90,000	57	125
ISP-J-W-16	18"	30"	16" Opening	(1) Non-Clogging Jet Burner	125,000	57	125
IISP-J-W-13	18"	30"	13" Opening	(1) Non-Clogging Jet Burner	125,000	59	130
ISP-J-SP	18"	24"	Top Grate w/ Cylinder	(1) Non-Clogging Jet Burner	125,000	62	135

Crated Dimensions: Height = 28" (712) Depth = 23" (585) Width: add 2 1/2" to unit width.

Standard Exterior Finish

- **Stainless Steel:** Front, sides and cabinet base.
- **Control Knobs:** Durable cast metal, polished chrome finish.
- **Cabinet Base:** Stainless steel cabinet base with 6" or 12" legs and adjustable feet.
- **Wok Top:** All-welded heavy 12 gauge steel. Welded-in (8" H) cylinder to concentrate and intensify heat. Painted finish.
- **Drip Tray:** Full width drip pan removes for cleaning.

Burners

- **Tempura Wok Burner:** High performance 3-ring burner with a total of 90,000 BTU/hr. provides even heating. Two adjustable gas valves.
- **Mandarin Wok Burner:** Non-clogging jet burner rated at 125,000 BTU/hr. provides cone-shaped intense heat. Knee-level "L" shaped handle conveniently adjusts gas. Keeps hands free for cooking.
- **Hi-Temp Stock Pot Burner:** Non-clogging jet burner rated at 125,000 BTU/hr. provides cone-shaped intense heat. Has adjustable gas valve. Heat is concentrated upward by a 12" high and 14" dia. cylinder that is welded into the top grate.

Optional Items

Various heights; wok openings; wok pans; casters (front two are locking). Quick disconnect and flexible gas hose. Stainless steel wok tops.

Interchangeable Tops

Tempura Wok top (ISP-18W) may be easily interchanged with top grate of ISPA-18 Stock Pot Range (see separate catalog sheet). Mandarin Wok top (ISP-J-W13) may be interchanged with Hi-Temp Stock Pot top grate with cylinder (ISP-J-SP). No tools are needed.

Gas

Manifold pressure is 5.0" W.C. for natural gas or 10.0" for propane gas. Manifold size 3/4" NPT. Specify type of gas and elevation if over 2000 ft.

Clearance

For use only on non-combustible surfaces. Provide 0" clearance from non-combustible surfaces and 17" from combustible surfaces.



Commercial Cooking Equipment

1560 Flower St., Duarte, CA 91010 Phone (626) 357-7411 FAX (626) 359-5909 E-Mail impsls@imperialrange.com Website imperialrange.com