



Project	Item Number	Quantity

MG0012	Duty Level	MG0012		
	<table border="1" style="width: 100%;"> <tr> <td style="background-color: black; color: white;">Light</td> <td>Medium</td> <td>Heavy</td> </tr> </table>	Light	Medium	Heavy
Light	Medium	Heavy		
		<p>Models:</p> <p><input type="checkbox"/> MG0012: 1/2hp Meat Grinder</p> <div style="text-align: center; margin-top: 20px;">  </div>		

Meat & Food Grinder	<p>Features</p> <ul style="list-style-type: none"> Light duty meat & food grinder Grinds 4 to 6 lbs. per minute on 1st grind with a 3/16" plate 1/2hp motor Gear driven Compact and portable. Unit only weighs 28 lbs. Perfect for small schools, nursing homes, and restaurants. Comes ready to grind with 3/16" grind plate, X-knife, stainless steel feed pan and poly stomper. Cord and plug 	<p>Standard Accessories</p> <ul style="list-style-type: none"> Stainless steel feed pan Poly stomper 3/16" grind plate X-knife <p>Optional Accessories</p> <ul style="list-style-type: none"> <input type="checkbox"/> 1000508 1/8" grind plate <input type="checkbox"/> 1000509 3/16" grind plate <input type="checkbox"/> 1000510 1/4" grind plate <input type="checkbox"/> 1000511 3/8" grind plate <input type="checkbox"/> 1000512 1/2" grind plate <input type="checkbox"/> 1000506 X-knife <input type="checkbox"/> 1000513 1/2" stuffing tube <input type="checkbox"/> 1000514 3/4" stuffing tube <input type="checkbox"/> 1000450 Small plastic cover
--------------------------------	--	---

Univex Corporation	<p>Warranty</p> <ul style="list-style-type: none"> 6-month, carry-in parts & labor warranty 	
---------------------------	---	--

WARRANTY DETAILS
 The MG0012 meat grinder carries a six-month, carry-in parts and labor warranty against any flaws in materials and workmanship. This period begins date of purchase and provided the unit is used in accordance with our instructions, is in full effect for one year from that date. Any work performed under this warranty must be performed between the hours of 8:00 a.m. and 5:00 p.m. local time, Monday through Friday. Univex will not pay for overtime charges for work performed other than during normal business hours. Damage incurred in transit or from installation error, accident, alteration or misuse is not covered. Univex shall not be liable for any consequential, compensatory, incidental, or special damages. Contact the Univex service department for any warranty claims.

Meat & Food Grinder

MG0012

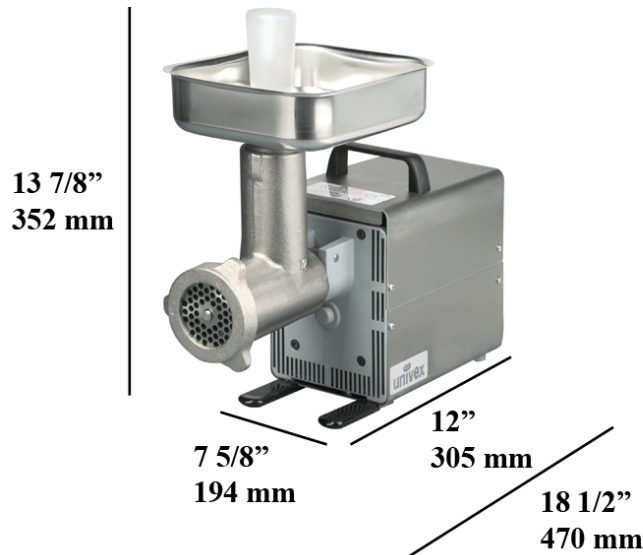

Dimensions

Overall width	7 5/8" (194mm)
Body length	12" (305mm)
Overall length	18 1/2" (470mm)
Overall height	13 7/8" (352mm)

Shipping Information

Freight Class:	85
Net Weight:	28 lb. (13 kg)
Shipping Weight:	32 lb. (14.5 kg)
Shipping Box Dimensions:	
Height:	13" (330mm)
Width:	14" (356mm)
Length:	18" (457mm)

Electrical: 115v, 60Hz, single phase. 208-240/60/1 & 220-240/50/1 available at no additional charge.

Motor: 1/2 HP capacitor start . 3360 RPM

Drive: 24:1 reduction produces high torque through a rugged gear box. 140 RPM drive shaft.

Drive Assembly: Completely enclosed in a 20 gauge stainless steel cover with a painted aluminum front panel

Switch: Toggle type double pole on/off conveniently located on left side of machine.

Meat Grinder: Electroless nickel plated cast iron housing with No.12 knife and plate. All parts are easy to remove for cleaning.

Feed Pan: 3 1/4" qt. (3 ltr.) capacity, 7 1/2" x 20" x 2 1/2" (190 x 254 x 64mm), stainless steel.

Feed Stomper: 18 1/2" x 13 1/2" (470 x 343mm) plastic.

Capacity: 4 to 6 lbs (2 to 3 kg) per minute on first grind using a plate with 3/16" (4mm) holes.

Optional Accessories:

The following are available at an extra cost:

1000508 1/8" Grind Plate

1000509 3/16" Grind Plate

1000510 1/4" Grind Plate

1000511 3/8" Grind Plate

1000512 1/2" Grind Plate

1000506 X-knife

1000513 1/2" Stuffing Tube

1000514 3/4" Stuffing Tube

1000450 Cover: Heavy-duty clear plastic cover for MG0012 grinder.